

DWG REF	QTY	PART NUMBER	DESCRIPTION	MATERIAL
<b>SHELL</b>				
1	1	172'9	SHELL	Filament Wound Epoxy/Glass composites - Head locking grooves integrally wound in place.
2	A/R	96327	3" Feed Port	SA-995 CD3MWCuN (J93380)
3	A/R	961'9	3" Port Seal	Sq-Seal-EPDM
4	1	17180	1" FNPT Drain Port	SA-995 CD3MWCuN (J93380)
5	1	45340	1" Port Seal	Sq-Seal-EPDM
<b>HEAD</b>				
6	1	17433	1/4" FNPT Air Vent Port	SA-479 UNS S32760
7	2	45286	1/4" Air Vent Port Seal	O - Ring - EPDM
8	1	17179	Bearing Plate Handle End	SB-221 6061-T6 Aluminium alloy - Hard anodized
9	1	17178	Sealing Plate Handle End	Engineering Thermoplastic - PVC*
10	1	17103	Bearing Plate Product End	SB-221 6061-T6 Aluminium alloy - Hard anodized
11	1	17126	Sealing Plate Product End	Engineering Thermoplastic - PVC*
12	1	17434	3" Product Port	SA-995 CD3MWCuN (J93380)
13.1	1	17432	3" Product Port Adapter	Engineering Thermoplastic - PVC*
13.2	1	17435	Product port holding pin	Engineering Thermoplastic
14	2	17164	3" Seal for Product Port Adapter	O - Ring - EPDM
15	1	17127	3" Port Retainer Ring	316 Stainless Steel.
16	2	96000	Head Seal	O - Ring - EPDM
17	1	17128	Product Port Seal	O - Ring - EPDM
18	1	17104	Handle Assembly	316 Stainless Steel
19	1	45247	Plug Retainer Ring	316L Stainless Steel
20	1	17132	Plug	Engineering Thermoplastic - PVC*
21	1	453'2	Plug seal	O - Ring - EPDM
<b>HEAD INTERLOCK</b>				
22	2	47336	Quick Release Spiral Ring	SA-479 316
<b>VESSEL SUPPORT</b>				
23	2	52169	Saddle	Engineering Thermoplastic
24	2	45042	Strap Assy.	304 Stainless Steel-PVC Cushion.
25	4	46265	Strap screw.	5/16-18 UNC, 18-8 Stainless Steel.

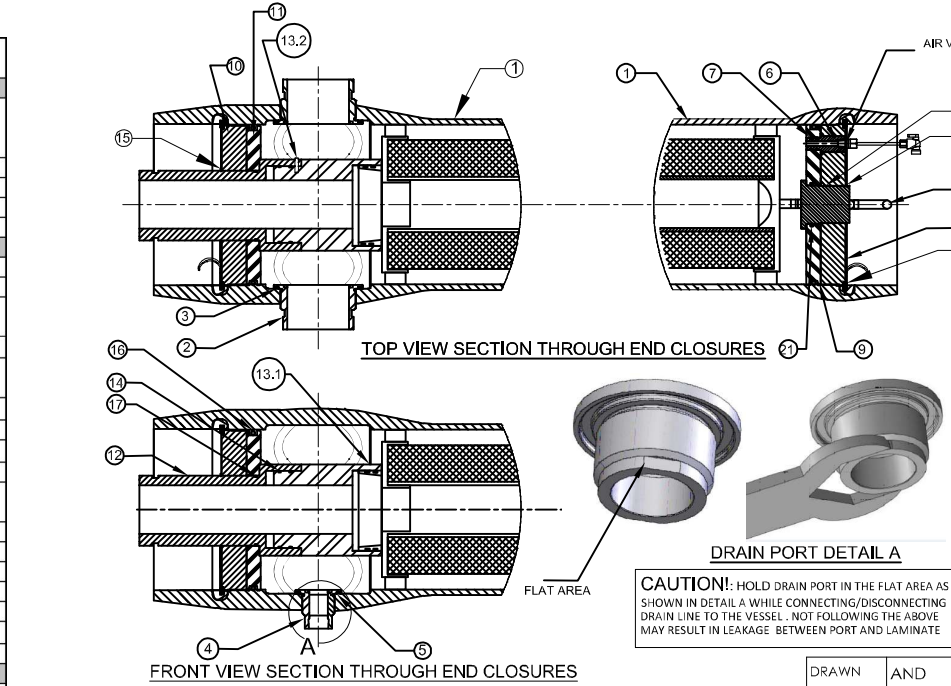

**Pentair Water India Pvt.Ltd**  
**CONTROLLED**  
 DCR / ECN No: **5280**  
 Sign & Date: **28/12/2019**

**AIR VENT ASSEMBLY:-17185**

ITEM	QUANTITY	PART NO.	DESCRIPTION
1	6" Long	RRS-01027	Tubing Blue
2	1	RRS-010013	Male Connector, Pipe 1/4" Tube 1/4"
3	2	RRS-01047	Compression nut 1/4"
4	1	RRS-01039	Ball Valve 1/4"
5	1	17194	Blind Plug 1/4"

Model	Approx Weight LB(KG)	Approx Weight With Filter LB(KG)
80CF15	60 (27)	73 (33)

**PENTAIR**  
**CODELINE®AQUALINE**

**MODEL-80CF15-60 (CODED)  
 SINGLE CARTRIDGE HOUSING**

DRAWN DATE	AND 22SEP10	DATE	24DEC19	DWG. NO.	17036	REV.	H
CHECKED DATE	RD 22SEP10	ECN	5280	SCALE	NONE	SIZE	A3
APPROVED DATE	RM 22SEP10	SHEET	1 OF 2				

**NOTES:-**  
 • DIMENSION IN INCHES (MM APPROX.)  
 • SHELL EXTERIOR COATED WITH WHITE, HIGH GLOSS POLYURETHANE PAINT.  
 • NOT TO BE USED FOR CONSTRUCTION UNLESS CERTIFIED.  
 • OPTIONAL MATERIAL SELECTION AVAILABLE FOR 180F APPLICATION ON SECOND PAGE.

**RATING:**

**PVC/PET**  
 DESIGN PRESSURE.....150 PSIG at 140°F/180°F  
 (1.03 MPa at 60°C / 82°C)  
 MIN. OPERATING TEMP.....20°F  
 (-7°C)  
 FACTORY TEST PRESSURE.....CE/ASME  
 225PSIG/165 PSIG  
 (1.55Mpa/1.13 MPa)  
 QUALIFICATION PRESSURE.....900 PSI  
 (6.20 MPa)

**INTENDED USE:**

The AquaLine 80CF15 Fiberglass Pressure Vessel is designed for continuous, long term use as housing for AquaLine range of micro filtration elements.

The AquaLine 80CF15 is designed in accordance with the engineering standards of the Boiler and Pressure Vessel Code of the American Society of Mechanical Engineers (ASME) as per Section X Edition 2019 and all metallic parts are designed as per Section VIII Division I Edition 2019. At small additional cost vessels can be inspected during construction by an ASME Authorized Inspector and ASME Code stamped.

The AquaLine 80CF15 must be installed, operated and maintained in accordance with the listed precautions and good industrial practice to assure safe operation over a long service life.

The high performance Filament wound FRP shell must be allowed to expand under pressure; undue restraint at support points or piping connections can cause leaks to develop in the shell. This side-ported vessel requires special precautions in mounting and connection to piping so that the vessel will not be subjected to excessive stress due to bending moments acting at the side openings in the fiberglass shell. The end closure, incorporating close fitting, interlocking metal components, must be kept dry and free of corrosion; deterioration can lead to catastrophic mechanical failure of the head.

Pentair will assist the purchaser in determining the suitability of this standard vessel for their specific operating conditions. The final determination however, including evaluation of the standard material of construction for compatibility with the specific corrosive environment, shall be the responsibility of the purchaser. Alternate materials with enhanced corrosion resistance are available on special order.

Specifications are subject to change without notice.

**PRECAUTIONS:**

- DO...read, understand and follow all instructions; failure to take every precaution will void warranty and may result in vessel failure.
- DO...mount the shell on horizontal members at span "S" using compliant vessel supports furnished; Shim saddles if required. Tighten hold down straps just snug
- DO...align and center side ports with the manifold header. Correct, causes of misalignment in a row of vessels connected to the same header.
- DO...use flexible type IPS grooved-end pipe couplings, or equal, at side ports; allow full, 0.125 inch gap between port and piping, and position piping to maximize flexibility of connection.
- DO...provide flexibility in, and support for piping manifolds so that vessel can grow in length under pressure without undue restraint; provide additional flexible joints in large pipes leading to manifold header.
- DO... Lubricate seals sparingly, using nonpetroleum Based lubricants, i.e. Parker Super O-lube®, Glycerin or suitable silicone based lubricants.
- DO...provide overpressure protection for vessel set at not more than 105% of design pressure.
- DO...inspect end closures regularly; replace components that have deteriorated and correct causes of corrosion.
- DO NOT...work on any component until first verifying that pressure is relieved from vessel.
- DO NOT...make rigid piping connections to ports or clamp vessel in any way that resists growth of fiberglass shell under pressure.
- DO NOT...pressurize vessel until double-checking to verify that the Locking Ring is in place and fully seated.
- DO NOT...operate vessel at pressure and temperature in excess of its rating.
- DO NOT...tolerate leaks or allow end closures to be routinely wetted in any way.
- DO NOT...operate outside the pH range of 3-11.

**ORDERING:**

Using the chart below, please check the features you require and fax them with your purchase order to our customer service department for further processing. For optional materials and / or feature not listed below, please consult the factory for pricing and availability.

**Pentair Water India Pvt.Ltd**

**CONTROLLED**

**DCR / ECN No: 5280**

**Sign & Date: 28/12/2019**

**VESSEL LENGTH CODE**

**MODEL:** AquaLine 80CF15-60

**CERTIFICATION REQUIRED**

- Certified by Pentair with Compliance to ASME Section X Hydro testing at 1.1 times.
- ASME code stamped and National Board Registered.
- CE Marking.

**HEAD ASSEMBLY MATERIAL SELECTION**

- Standard: For 140°F application, Engineering Thermoplastic components in PVC as per drawing 17036 on First page.
- Option: For 180°F application, Engineering Thermoplastic components in PET as given below. (Please consult factory as these options will affect pricing and vessel lead time).

HEAD COMPONENTS FOR 180°F APPLICATION				
DWG REF	QTY		DESCRIPTION	MATERIAL
6	1	17433	1/4" FNPT Air Vent Port	SA-479 UNS S32760.
7	2	45286	1/4" Air Vent Port Seal	O - Ring - EPDM
8	1	17179	Bearing Plate Downstream	SB-221 6061-T6 Aluminium alloy - Hard anodized.
9	1	17404	Sealing Plate Downstream	Engineering Thermoplastic - PET.
10	1	17103	Bearing Plate Upstream	SB-221 6061-T6 Aluminium alloy - Hard anodized.
11	1	17453	Sealing Plate Upstream	Engineering Thermoplastic - PET.
12	1	17434	3" Product Port	SA-995 CD3MWCuN (J93380)
13.1	1	17452	3" Product Port Adapter	Engineering Thermoplastic - PET.
13.2	1	17435	Product port holding pin	Engineering Thermoplastic
14	2	17164	3" Seal for Product Port Adapter	Ethylene Propylene - O - Ring
15	1	17127	3" Port Retainer Ring	316 Stainless Steel.
16	2	96000	Head Seal	Ethylene Propylene O - Ring
17	1	17128	Product Port Seal	Ethylene Propylene O - Ring
18	1	17104	Handle Assembly	316 Stainless Steel
19	1	45247	Plug Retainer Ring	316L Stainless Steel
20	1	17407	Plug	Engineering Thermoplastic - PET.
21	1	45312	Plug seal	Ethylene Propylene O - Ring

**FEED PORT CONFIGURATION**

PORT SIZE CODE	
A	1" FNPT END
G	3" GROOVED END

Please fill out quantity for each configuration

- 1A 4G – Standard
- 1A 2G – (Optional)
- 1A 2G 4G – (Optional)

For complete information on proper use of the vessel  
 Please refer to the AquaLine User Guide No 97676.

