

4 3 2 1

150
PSI

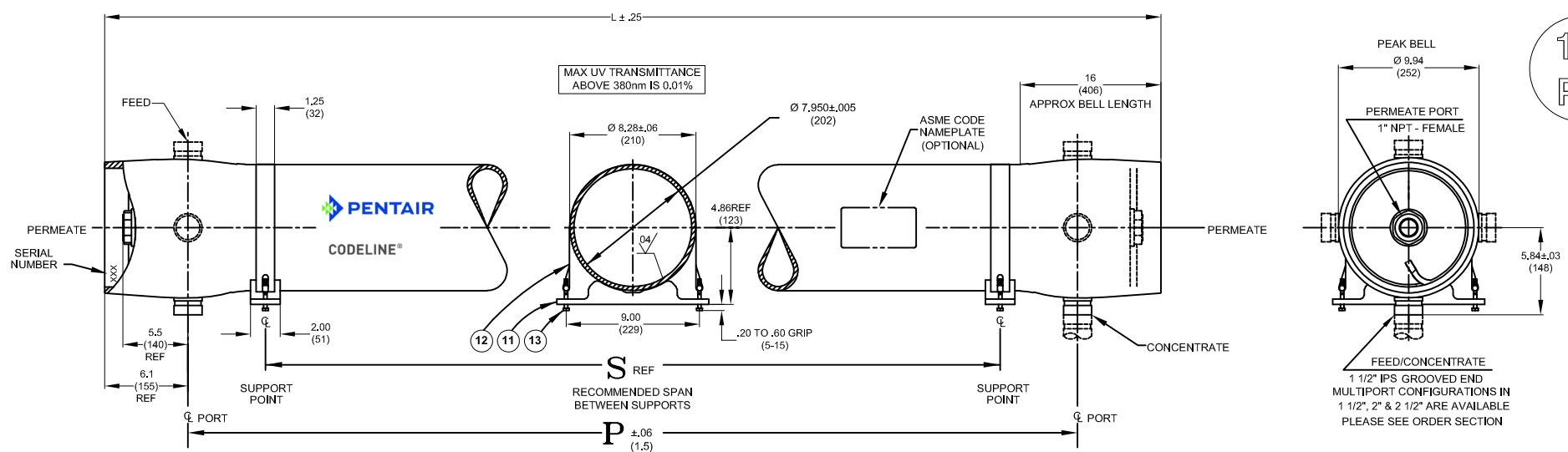

DWG REF	QTY	PART NUMBER	DESCRIPTION	MATERIAL
SHELL				
1	1	99230	SHELL	Filament Wound Epoxy/Glass composite - Head locking grooves integrally wound in place.
2	A/R	A/R	F/C Port	SA-351 CF3M
3	A/R	A/R	F/C Port Seal	Ethylene Propylene.
HEAD				
4	2	194682	Bearing Plate Assembly	-
4.1	1	194609	Bearing Plate	SB-108 A03560-T6
4.2	1	196057	Danger Label	-
5	2	96160	Sealing Plate	Engineering Thermoplastic.
6	2	96162	Permeate Port	Engineering Thermoplastic.
7	2	45066	Port Nut	Engineering Thermoplastic.
8	2	96000	Head Seal	Ethylene Propylene - O - Ring
9	2	45312	Perm Port Seal	Ethylene Propylene - O - Ring
HEAD INTERLOCK				
10	2	47336	Quick Release Spiral Ring	SA-479 316
VESSEL SUPPORT				
11	2+	52169	Saddle	Engineering Thermoplastic.
12	2+	45042	Strap Assy.	304 Stainless Steel-PVC Cushion.
13	4**	46265	Strap screw.	5/16-18 UNC, 2.5"-L, 18-8 Stainless Steel.
ELEMENT INTERFACE				
14	2	A/R	Adapter	Engineering Thermoplastic.
15	2	52245	Adapter seal	Ethylene Propylene - O - Ring
16	4	A/R	PWT Seal	Ethylene Propylene - O - Ring
17	1	96163	Thrust Cone	Engineering Thermoplastic.

*3 & **6 each furnished with length code 4,5,6,7 & 8.

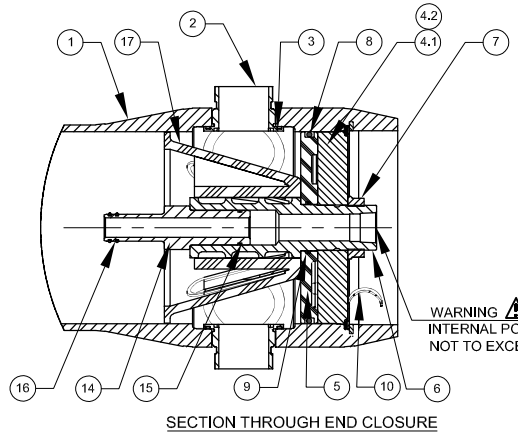

NOTES:-

- MAX. ANGULAR VARIATION BETWEEN ANY PORTS ±0.5°.
- DIMENSION IN INCHES (MM APPROX.)
- SHELL EXTERIOR COATED WITH WHITE RAL 9003, HIGH GLOSS POLYURETHANE PAINT.
- ITEM 17 DOWNSTREAM ONLY.
- NOT TO BE USED FOR CONSTRUCTION UNLESS CERTIFIED BY PENTAIR.
- FOR OPTIONAL PART NUMBERS, REFER PAGE 3.
- # 150 PSI FOR METALLIC PERMPORTS
- ** WEIGHTS GIVEN IN THE TABLE ARE FOR HIGHEST CONFIGURATION AND WILL VARY WITH CHANGE IN CONFIGURATION.

CAUTION: INCORRECT MANIFOLDING WILL CAUSE SEVERE LOCAL STRESS AROUND PORT AND MAY RESULT IN LEAKS AND PREMATURE FAILURE. TAKE EVERY PRECAUTION LISTED ON REVERSE, SEE INSTALLATION INSTRUCTIONS FOR FURTHER DETAILS

PORT CONFIGURATION DETAILS	
PORT CONFIG	VESSEL QUANTITY

PO NUMBER	
CUSTOMER NAME	
PROJECT NAME	
TOTAL QUANTITY	

Dash Length	L IN(MM)	P IN(MM)	S IN(MM)	Approx Weight LB(KG)**
-1	59.15 (1502)	47 (1194)	23X1 (584)	55 (25)
-2	99.15 (2518)	87 (2210)	56X1 (1422)	64 (29)
-3	139.15 (3534)	127 (3226)	80X1 (2032)	73 (33)
-4	179.15 (4550)	167 (4242)	64X2 (1626)	82 (37)
-5	219.15 (5566)	207 (5258)	78X2 (1981)	90 (41)
-6	259.15 (6582)	247 (6274)	92X2 (2337)	99 (45)
-7	299.15 (7598)	287 (7290)	106X2 (2692)	108 (49)
-8	339.15 (8614)	327 (8306)	120X2 (3048)	117 (53)

DRAWN DATE	PGS
17 MAR 07	17 MAR 07
CHECKED DATE	MD
17 MAR 07	17 MAR 07
APPROVED DATE	RM
17 MAR 07	17 MAR 07

PENTAIR

CODELINE®

MODEL - 80S15
MEMBRANE HOUSING

ECN 5300	DWG. NO. 99159	REV. U
DATE 20JAN2020	SCALE NONE	SIZE A3 SHEET 1 OF 3

4 3 2 1

RATING:

DESIGN PRESSURE.....150 PSIG
(1.0 MPa)
 MAX. OPERATING TEMP.....190°F
(88°C)
 MIN. OPERATING TEMP.....20°F
(-7°C)
 FACTORY TEST PRESSURE..... CE/ASME
 225 PSIG /165 PSIG
(1.6 MPa)(1.1MPa)
 QUALIFICATION PRESSURE900 PSI
(6.2 MPa)

INTENDED USE:

The CodeLine 80S15 Fiberglass RO Pressure Vessel is designed for continuous, long term use as housing for reverse osmosis membrane elements to desalt typical brackish waters at pressures up to 150 psi. Any make of eight-inch nominal diameter spiral-wound element is easily accommodated; the appropriate interfacing hardware for the element specified is furnished with the vessel.

The CodeLine 80S15 is designed in accordance with the engineering standards of the Boiler and Pressure Vessel Code of the American Society of Mechanical Engineers (ASME) as per Section X Edition 2019. F/C port, Bearing plate and Quick release spiral ring are designed as per Section VIII Division I Edition 2019.

At small additional cost vessels can be inspected during construction by an ASME Authorized Inspector and ASME Code stamped.

The CodeLine 80S15 must be installed, operated and maintained in accordance with the listed precautions and good industrial practice to assure safe operation over a long service life.

The high performance Filament wound FRP shell must be allowed to expand under pressure; undue restraint at support points or piping connections can cause leaks to develop in the shell. This side-ported vessel requires special precautions in mounting and connection to piping so that the vessel will not be subjected to excessive stress due to bending moments acting at the side openings in the fiberglass shell. The end closure, incorporating close fitting, interlocking metal components, must be kept dry and free of corrosion; deterioration can lead to catastrophic mechanical failure of the head.

Pentair will assist the purchaser in determining the suitability of this standard vessel for their specific operating conditions. The final determination however, including evaluation of the standard material of construction for compatibility with the specific corrosive environment, shall be the responsibility of the purchaser. Alternate materials with enhanced corrosion resistance are available on special order.

Specifications are subject to change without notice.

PRECAUTIONS:

- DO...read, understand and follow all instructions; failure to take every precaution will void warranty and may result in vessel failure
- DO...mount the shell on horizontal members at span “S” using compliant vessel supports furnished; Shim saddles if required. Tighten hold down straps just snug
- DO...align and center side ports with the manifold header. Correct, causes of misalignment in a row of vessels connected to the same header
- DO...use flexible type IPS grooved-end pipe couplings, at side ports; allow full, 0.125 inch gap between port and piping, and position piping to maximize flexibility of connection.
- DO...provide flexibility in, and support for piping manifolds so that vessel can grow in length under pressure without undue restraint; provide additional flexible joints in large pipes leading to manifold header.
- DO...provide overpressure protection for vessel set at not more than 105% of design pressure
- DO...inspect end closures regularly; replace components that have deteriorated and correct causes of corrosion
- DO... Lubricate seals sparingly, using nonpetroleum based lubricants, i.e. Glycerin or suitable lubricants.

DO NOT...work on any component until first verifying that pressure is relieved from vessel

DO NOT...make rigid piping connections to ports or clamp vessel in any way that resists growth of fiberglass shell under pressure;

***ΔDIA = 0.015 in. (0.4mm) and

***AL = 0.2 in. (5mm) for a length code –8 vessel

DO NOT... hang piping manifolds from ports or use vessel in any way to support other components

DO NOT...tighten Permeate Port connection more than one turn past hand tight

DO NOT... operate vessel without connecting both Permeate Ports internally to complete set of elements or otherwise plug ports internally so that external piping connection is not subjected to feed pressure

DO NOT...install Spacer on downstream end of vessel

DO NOT...operate vessel without Thrust Cone installed downstream

DO NOT...pressurize vessel until double-checking to verify that the Locking Ring is in place and fully seated.

DO NOT...operate vessel at pressure and temperature in excess of its rating.

DO NOT...operate vessel with permeate pressure in excess of 125 psi at 190°F (0.86 Mpa at 88°C).

DO NOT...tolerate leaks or allow end closures to be routinely wetted in any way

DO NOT...operate outside the pH range 3-11.

For complete information on proper use of the vessel Please refer to the 80S Series USER’S GUIDE 94182.

ORDERING:

Using the chart below, please check the features you require

VESSEL LENGTH CODE – please check one

MODEL 80S15 -1 -2 -3 -4 -5 -6 -7 -8

MEMBRANE BRAND AND MODEL

Please supply adapters for the following membrane brand and specific model
 Brand _____ Model _____

CERTIFICATION REQUIRED

- Hydro testing at 1.1 times the design pressure.
 - ASME Stamped and National Board Registered.
 - In compliance with the ASME Sec X but not Code Stamped.
- Hydro testing at 1.5 times the design pressure.
 - CE Marked

PERMEATE PORT SELECTION

Serial Number End

Size of the Permeate Port 1” 1.25” 1.5”

Type of Connection FNPT MNPT BSPTM BSPTF IPS GROOVED TRI-CLOVER

Material of Construction Noryl SS316L Zeron 100

Non Serial Number End

Size of the Permeate Port 1” 1.25” 1.5”

Type of Connection FNPT MNPT BSPTM BSPTF IPS GROOVED TRI-CLOVER

Material of Construction Noryl SS316L Zeron 100

Note:

- Standard offering is 1.0” FNPT in Noryl.
- 1.25”& 1.5” BSPTF, 1.25” & 1.5” FNPT and 1.25” TRI-CLOVER connections cannot be offered.
- TRI-CLOVER permeate port cannot be offered in Noryl.

STRAP ASSEMBLY

SS304 SS316 SS316L

FEED/CONCENTRATE PORT SELECTION

Material of Construction CF3M Duplex (CD3MN)
 Super Duplex (CD3MWCuN)

Configuration CF3M 1D5D
 Multi ports :(Refer SPEC.SHEET/PM/1.5”-3”for Multi port selection)

Serial number end

Opposite end

BEARING PLATE MATERIAL

- A03560 T6 Aluminum
- A96061 T6 Aluminum
- Stainless Steel 316L

Note: Please refer to 99321 for Tri-clover details and refer page-3 for optional Part numbers.

ADAPTER KITS	
UP STREAM	DOWN STREAM

PORT SIZE CODE	
D	1½” GROOVED END
E	2” GROOVED END
F	2½” GROOVED END

4

3

2

1

BEARING PLATE PART NUMBERS			
PERMEATE PORT SIZE	ALUMINIUM		SS F316L ###
	SB-108 UNS A03560-T6	SB-221 UNS A96061-T6	
1.0"/1.25"	194682	194446	194508
1.5"	-	194477	194539

SEALING PLATE PART NUMBERS	
Standard used for Aluminium BP	96160
Optional used for SS316L BP	96477

PERM PORT RETAINER RING & PORT NUT PART NUMBERS		
1.0" / 1.25"	Standard Port nut	45066
1.5"	Port Retainer Ring	45247

STRAP ASSEMBLY PART NUMBERS		
SS304	SS316	SS316L
45042	46926*	94371*

F/C PORT & SEAL PART NUMBER				
SIZE	*CF3M	**CD3MN	***CD3MWCuN	SEAL
1.5"	98024	97353	96507	96077
2.0"	98025	97357	96643	96078
2.5"	98026	97364	96556	96079

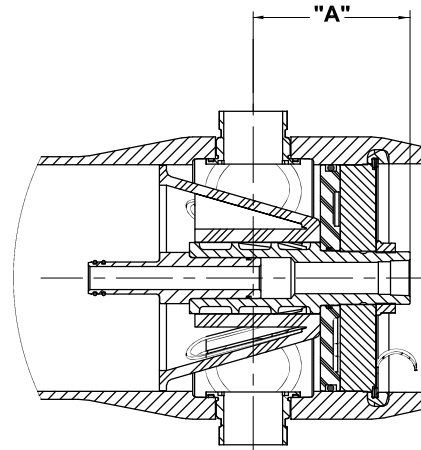

SECTION THROUGH END CLOSURE

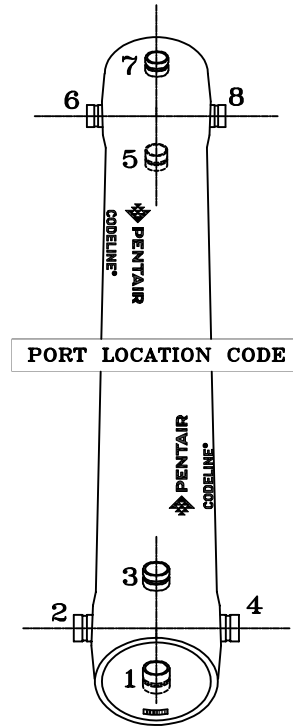

Serial Number End

CODELINE BODY LABELS ARE PLACED AT 90° ON SERIAL NUMBER END AND AT 270° ON THE OPPOSITE SIDE END

PERMEATE PORT PART NUMBERS & PERMPORT TO F/C PORT OFFSET DISTANCE											
SIZE	MATERIAL	FNPT		MNPT		BSPTF		BSPTM		IPS GROOVED	
		PART NUMBER	DIM "A"	PART NUMBER	DIM "A"	PART NUMBER	DIM "A"	PART NUMBER	DIM "A"	PART NUMBER	DIM "A"
1.0"	NORYL	96162	5.5	97659	6.5	96301	5.5	97660	6.5	97661	6.8
	SS316L # #	96752	5.5	97347	6.5	97351	5.5	97355	6.5	97322	6.8
	#ZERON 100	97349	5.5	97348	6.5	97352	5.5	97356	6.5	97293	6.8
1.25"	NORYL	NA	NA	97655	6.5	NA	NA	97360	6.5	97662	6.8
	SS316L # #	NA	NA	96487	6.5	NA	NA	97362	6.5	97311	6.8
	#ZERON 100	NA	NA	97359	6.5	NA	NA	97363	6.5	97365	6.8
1.5"	NORYL	NA	NA	97663	6.1	NA	NA	97369	6.1	97656	6.7
	SS316L # #	NA	NA	97368	6.1	NA	NA	97371	6.1	97449	6.7
	#ZERON 100	NA	NA	97292	6.1	NA	NA	97372	6.1	97374	6.7

NOTES

- ◆ DIMENSION IN INCHES (MM APPROX.)
- * GRADE SA-351 CF3M
- ** GRADE SA-995 CD3MN, UNS J92205
- *** GRADE SA-995 CD3MWCuN, UNS J93380
- # GRADE SA-479 UNS S32760 / S32750
- ## GRADE SA-479 316L
- ### GRADE SA-182 F316L
- + OPTIONAL STRAP ASSEMBLY WITH 316 & 316L STAINLESS STEEL MATERIAL SHALL BE SUPPLIED AS PER METRIC STANDARDS.

PENTAIR
CODELINE®

DRAWN	PDM 27 JUN 11	MODEL - 80S15 MEMBRANE HOUSING		
CHECKED	RD 27 JUN 11	DATE	DWG. NO.	REV.
APPROVED	RM 27 JUN 11	20JAN2020	99159	U
		ECN 5300	SCALE NONE	SIZE A3 SHEET 3 OF 3

4

3

2

1